

skate park



Skate park Equipment

Skate park 4

◀ 25m ▶

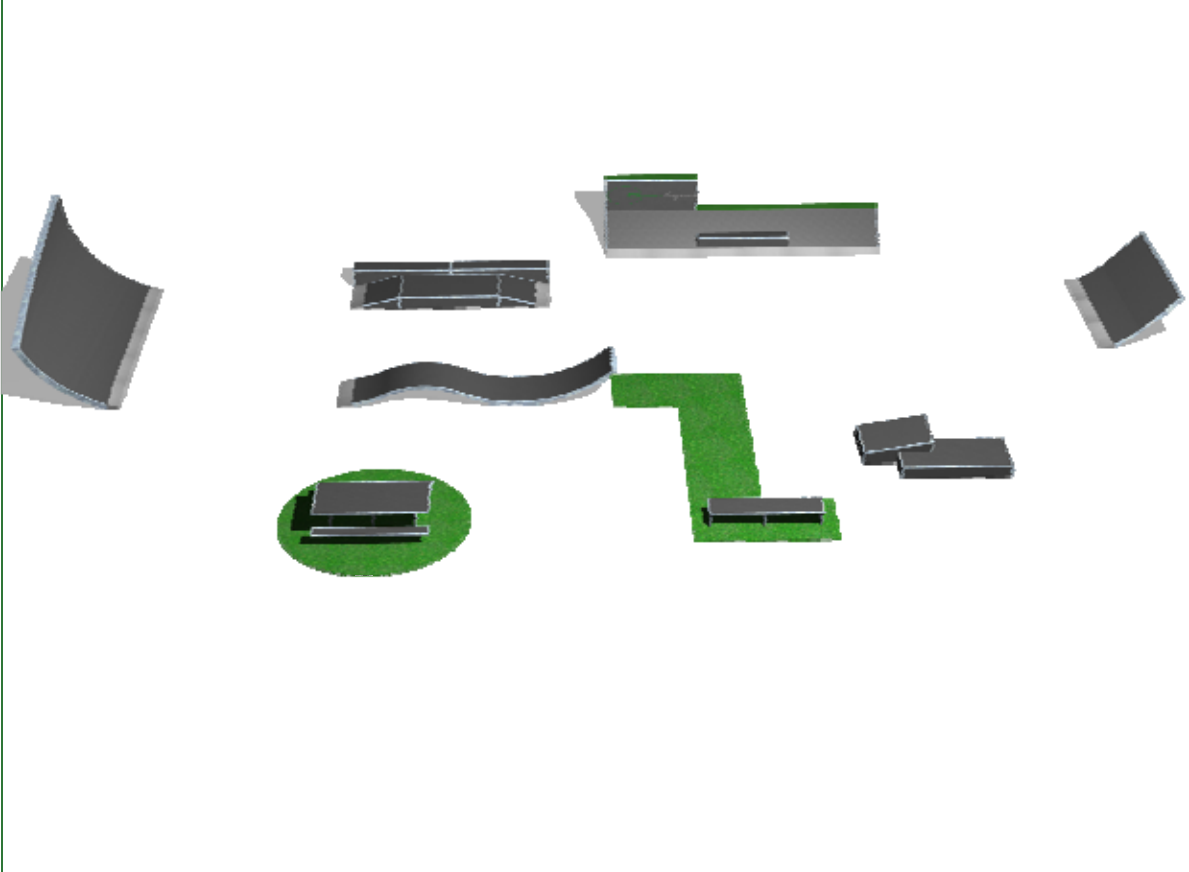

▲
16m
▼

| | L | B | m ² | | GFK | Beton |
|----------------|-------|-------|----------------|-----|-----------------------|-----------------------|
| Gesamt: | 25,00 | 16,00 | 400 | Nr. | 0,00 Sp-4-K | 0,00 Sp-4-C |

Skate park 6

◀ 30m ▶

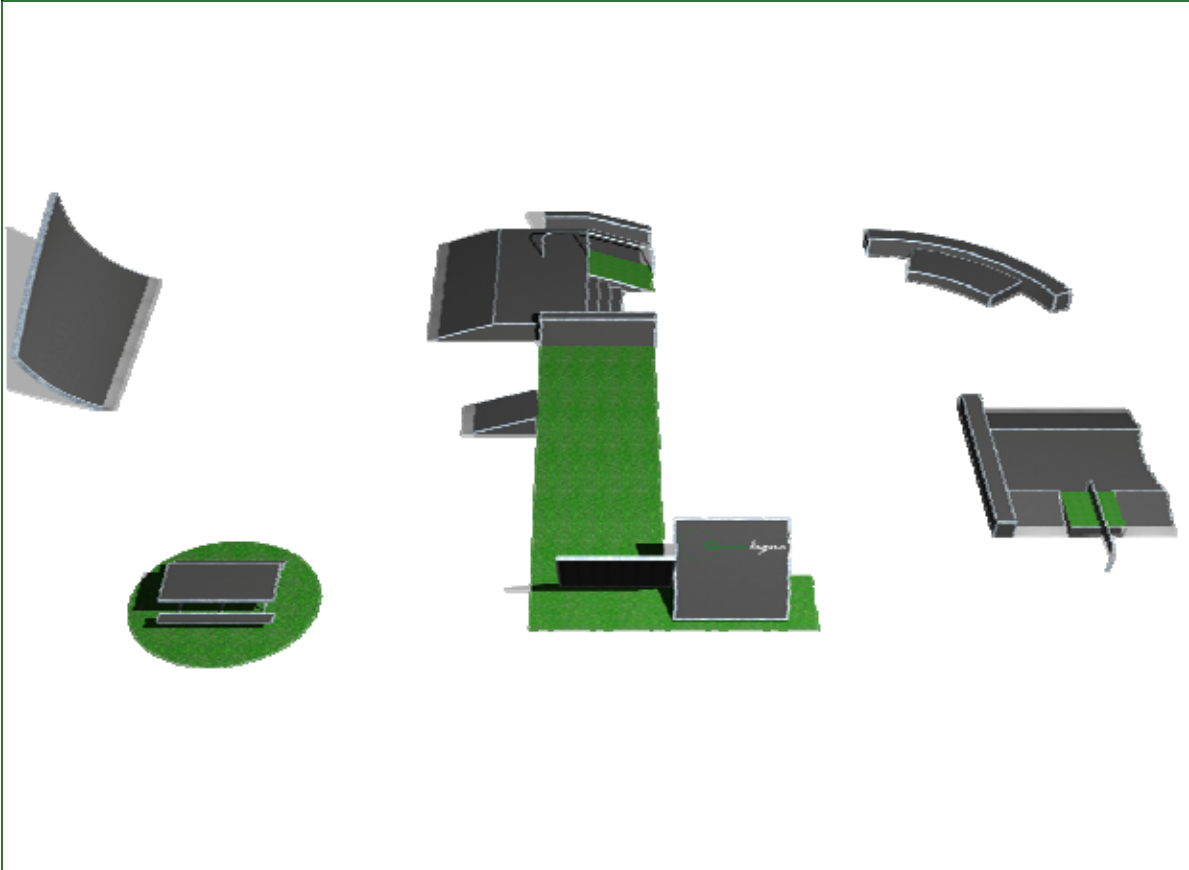

▲
20m
▼

| | L | B | m ² | | GFK | Beton |
|----------------|-------|-------|----------------|-----|-----------------------|-----------------------|
| Gesamt: | 30,00 | 20,00 | 600 | Nr. | 0,00 Sp-6-K | 0,00 Sp-6-C |

Skate park Equipment

skate park 8

◀ 25m ▶

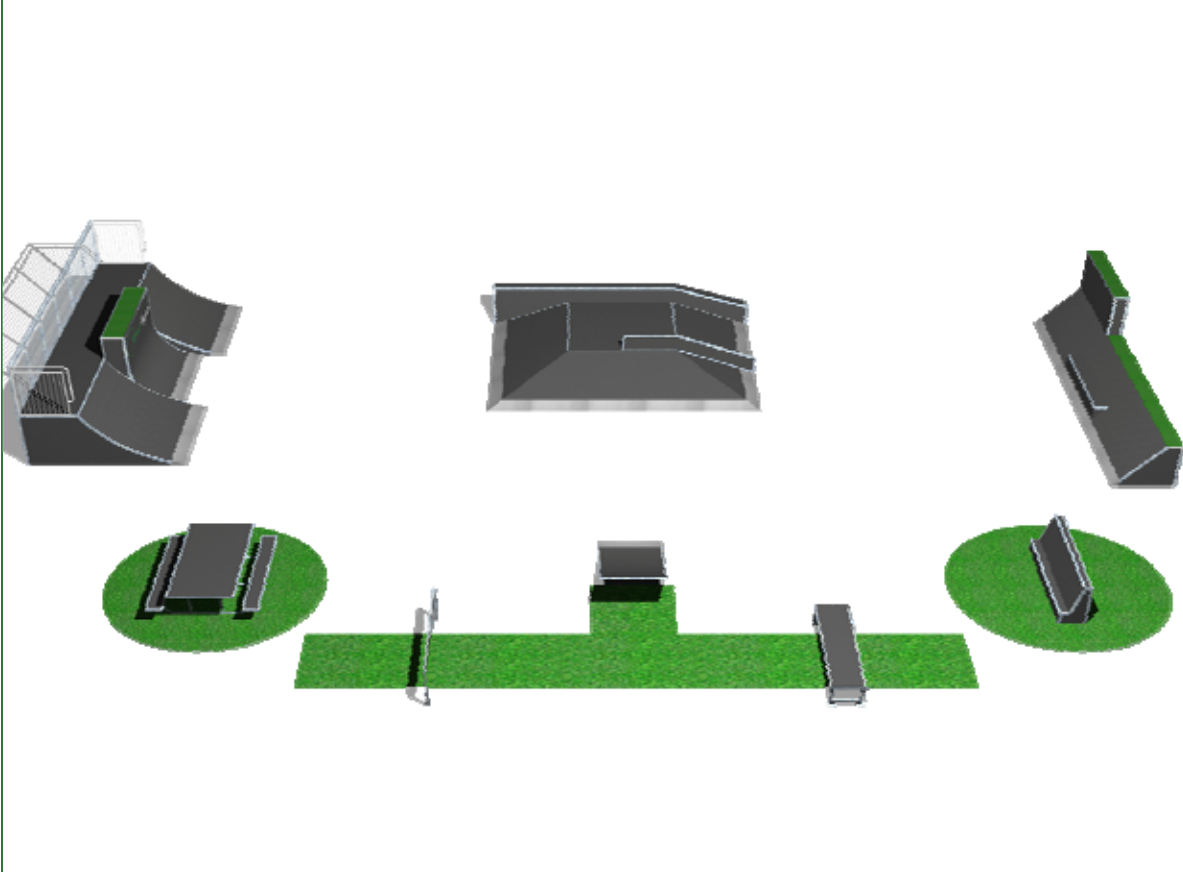

▲
22m
▼

| | L | B | m ² | | GFK | Beton |
|----------------|-------|-------|----------------|-----|------------------------|------------------------|
| Gesamt: | 25,00 | 22,00 | 550 | Nr. | 0,00 Sp-P8-K | 0,00 Sp-P8-C |

Plaza 2

◀ 30m ▶

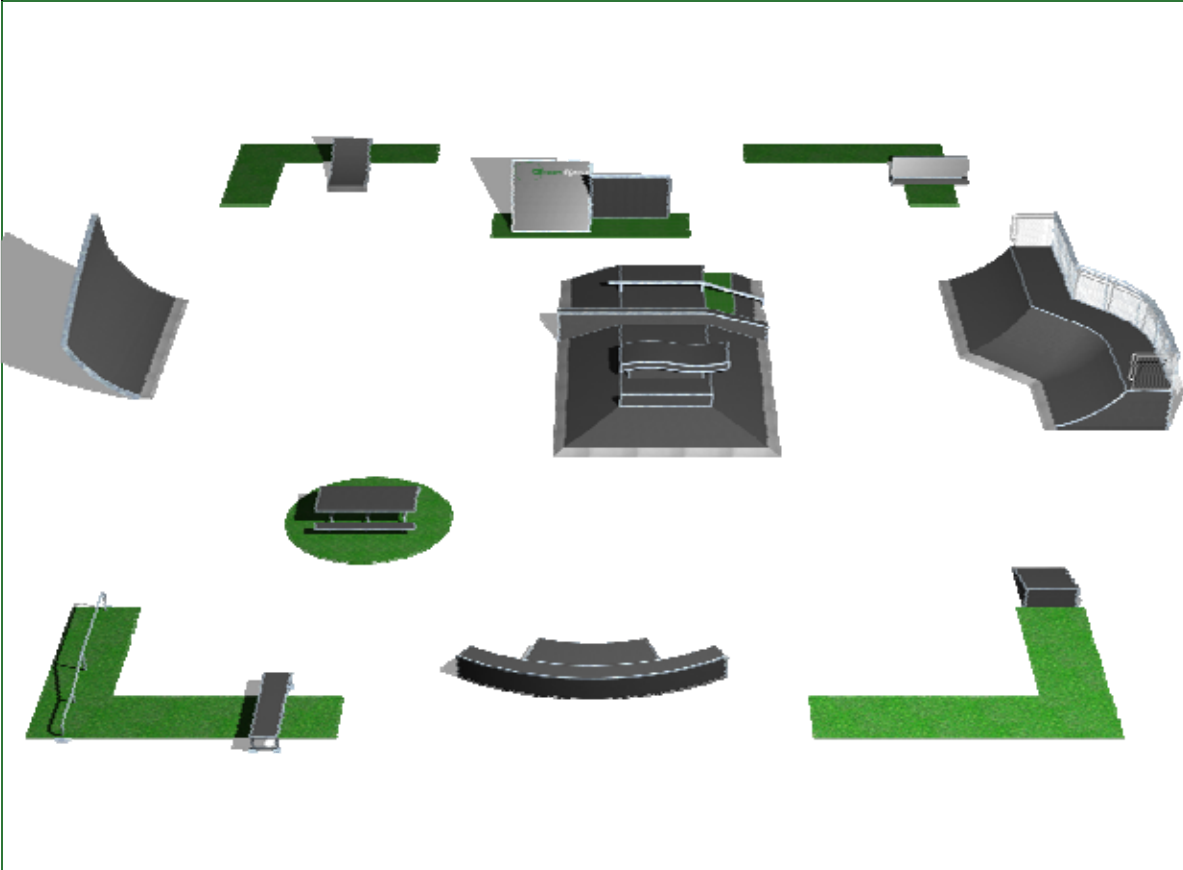

▲
40m
▼

| | L | B | m ² | | GFK | Beton |
|----------------|-------|-------|----------------|-----|------------------------|------------------------|
| Gesamt: | 30,00 | 40,00 | 1200 | Nr. | 0,00 Sp-P2-K | 0,00 Sp-P2-C |

Skate park Equipment

Plaza 3

◀ 35m ▶

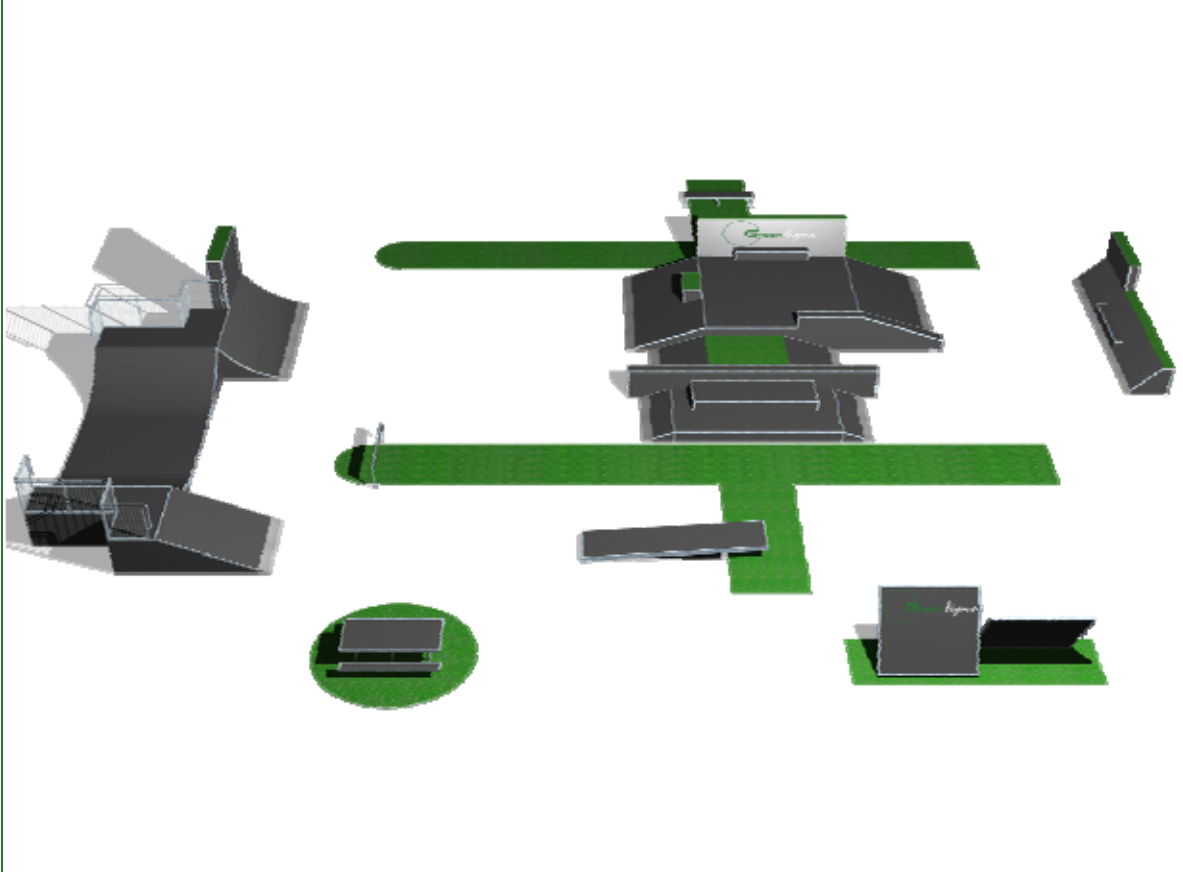

▲
30m

▼

| | L | B | m ² | | GFK | Beton |
|----------------|-------|-------|----------------|-----|------------------------|------------------------|
| Gesamt: | 35,00 | 30,00 | 1050 | Nr. | 0,00 Sp-P3-K | 0,00 Sp-P3-C |

street 1

◀ 30m ▶

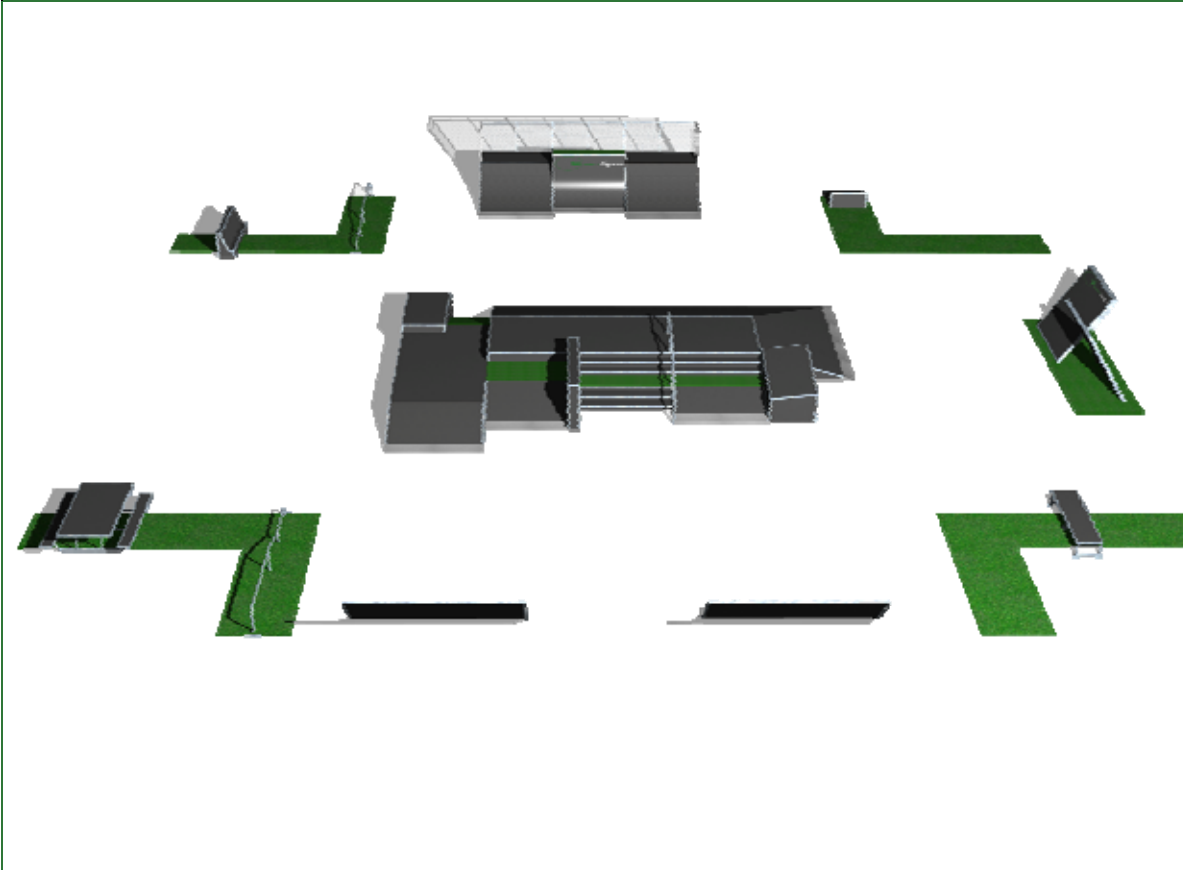

▲
40m

▼

| | L | B | m ² | | GFK | Beton |
|----------------|-------|-------|----------------|-----|------------------------|------------------------|
| Gesamt: | 30,00 | 40,00 | 1200 | Nr. | 0,00 Sp-S1-K | 0,00 Sp-S1-C |

Obstacles

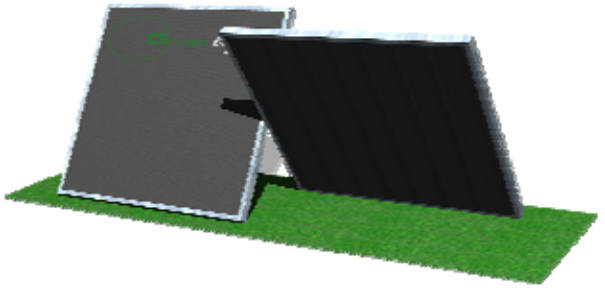
| X-treme | L | B | H | Fahrbelag | | |
|---|---------------------------|------|------|-----------|-------------|-------------|
| | | | | GFK | Beton | |
|  | 4,80 | 1,20 | 1,00 | Nr. | 0,00 | 0,00 |
| | 01-1200100-K 01-1200100-C | | | | | |

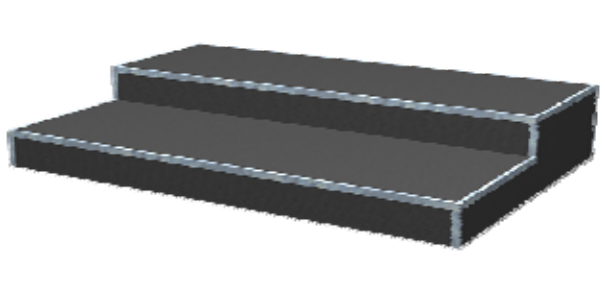
| Ollie-Box | L | B | H | Nr. | GFK | Beton |
|---|---------------------------|------|--------------|-----|-------------|-------------|
|  | 3,60 | 2,40 | 0,25 0,50 | | 0,00 | 0,00 |
| | 02-1200050-K 02-1200050-C | | | | | |

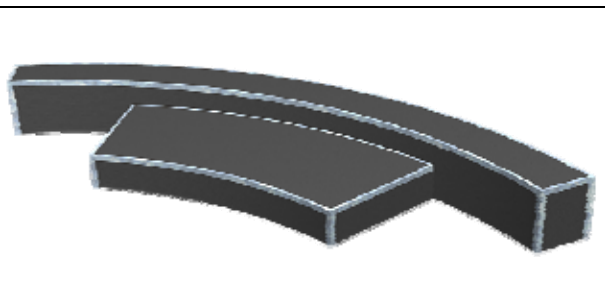
| rounded Curb | L | B | H | Nr. | GFK | Beton |
|--|---------------------------|------|--------------|-----|-------------|-------------|
|  | 5,80 | 1,80 | 0,35 0,60 | | 0,00 | 0,00 |
| | 03-1200060-K 03-1200060-C | | | | | |

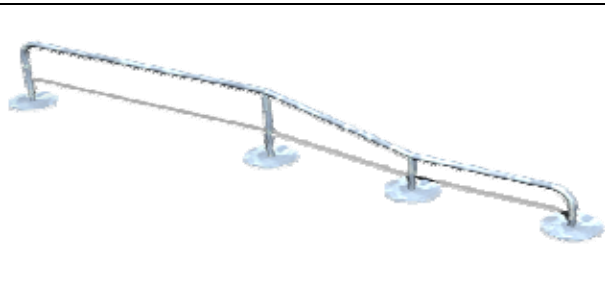
| Rail B | L | B | H | Nr. | GFK | Beton |
|---|------------|---|--------------|-----|-------------|-------|
|  | 4,80 | | 0,30 0,50 | | 0,00 | |
| | 04-0480050 | | | | | |

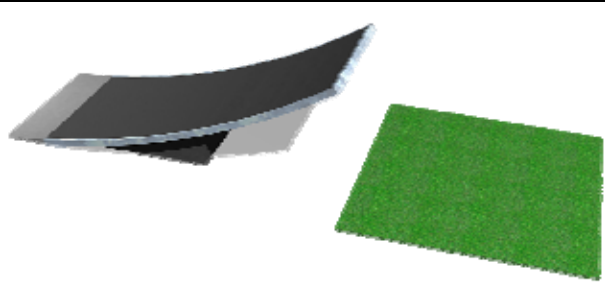
| Kicker | L | B | H | Nr. | GFK | Beton |
|---|---------------------------|------|------|-----|-------------|-------------|
|  | 2,40 | 1,20 | 0,90 | | 0,00 | 0,00 |
| | 05-1200090-K 05-1200090-C | | | | | |

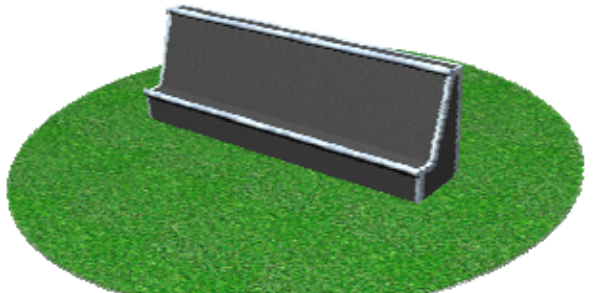
| Barrier | L | B | H | Nr. | GFK | Beton |
|---|---------------------------|------|------|-----|-------------|-------------|
|  | 2,40 | 0,50 | 0,80 | | 0,00 | 0,00 |
| | 06-0500080-K 06-0500080-C | | | | | |

urban street furniture

picnic Table

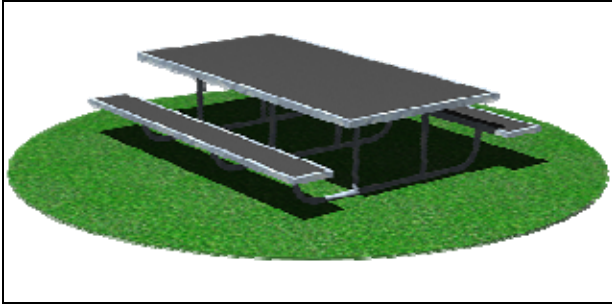

| | | | | Fahrbelag | |
|------|------|------|-----|-----------------------------|-----------------------------|
| L | B | H | | GFK | Beton |
| 2,40 | 1,80 | 0,60 | Nr. | 0,00 07-1200060-K | 0,00 07-1200060-C |

new Wave

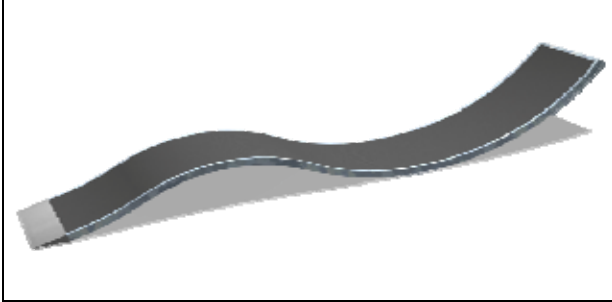

| | | | | | |
|------|------|--------------|-----|-----------------------------|-----------------------------|
| 6,30 | 1,20 | 0,60 0,90 | Nr. | 0,00 08-1200090-K | 0,00 08-1200090-C |
|------|------|--------------|-----|-----------------------------|-----------------------------|

Bench



| | | | | | |
|------|------|------|-----|-----------------------------|-----------------------------|
| 2,40 | 0,60 | 0,40 | Nr. | 0,00 09-0600040-K | 0,00 09-0600040-C |
|------|------|------|-----|-----------------------------|-----------------------------|

manual Bad

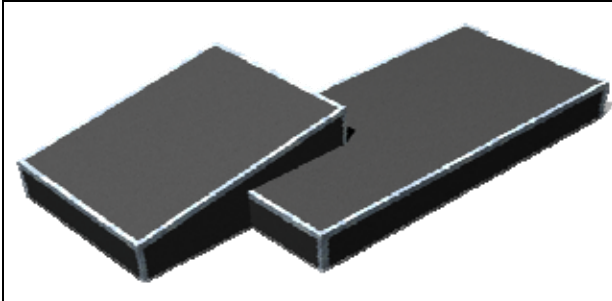

| | | | | | |
|------|------|--------------|-----|-----------------------------|-----------------------------|
| 3,20 | 1,80 | 0,35 0,60 | Nr. | 0,00 10-0600040-K | 0,00 10-0600040-C |
|------|------|--------------|-----|-----------------------------|-----------------------------|

manual Bad II

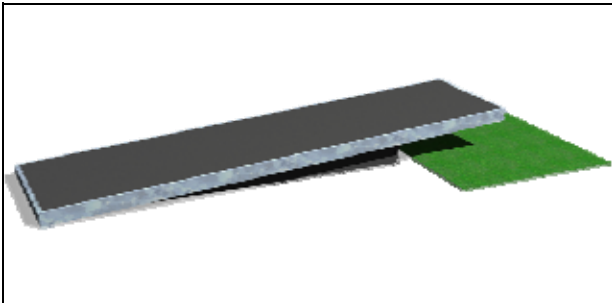

| | | | | | |
|------|------|------|-----|-----------------------------|-----------------------------|
| 4,80 | 1,20 | 0,60 | Nr. | 0,00 11-1200060-K | 0,00 11-1200060-C |
|------|------|------|-----|-----------------------------|-----------------------------|

Bank

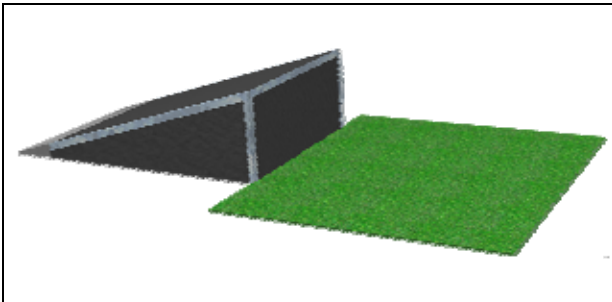

| | | | | | |
|------|------|------|-----|-----------------------------|-----------------------------|
| 1,80 | 1,20 | 0,60 | Nr. | 0,00 12-1200060-K | 0,00 12-1200060-C |
|------|------|------|-----|-----------------------------|-----------------------------|

Fun-Box

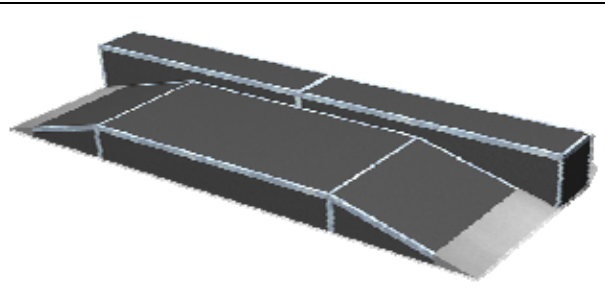
| Launch-Box II | L | B | H | Fahrbelag | | |
|---|------|------|------|-----------|--------------|--------------|
| | | | | GFK | Beton | |
|  | 4,80 | 1,70 | 0,35 | Nr. | 0,00 | 0,00 |
| | | | | | 13-1200035-K | 13-1200035-C |

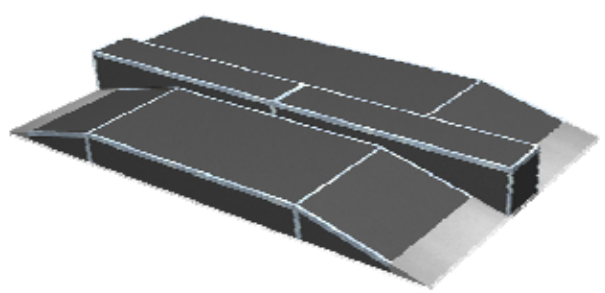
| Launch-Box VI | L | B | H | Fahrbelag | | |
|---|------|------|------|-----------|--------------|--------------|
| | | | | GFK | Beton | |
|  | 4,80 | 2,90 | 0,35 | Nr. | 0,00 | 0,00 |
| | | | | | 14-1200035-K | 14-1200035-C |

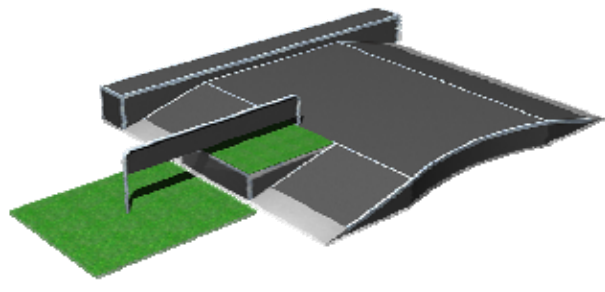
| Fun-Box mit Rail und Curb | L | B | H | Fahrbelag | | |
|--|------|------|------|-----------|--------------|--------------|
| | | | | GFK | Beton | |
|  | 4,80 | 4,20 | 0,35 | Nr. | 0,00 | 0,00 |
| | | | | | 15-1200060-K | 15-1200060-C |

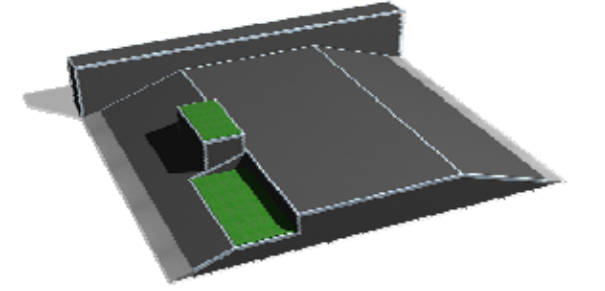
| Custom 2 | L | B | H | Fahrbelag | | |
|---|------|------|------|-----------|--------------|--------------|
| | | | | GFK | Beton | |
|  | 5,30 | 6,00 | 0,60 | Nr. | 0,00 | 0,00 |
| | | | | | 16-1200060-K | 16-1200060-C |

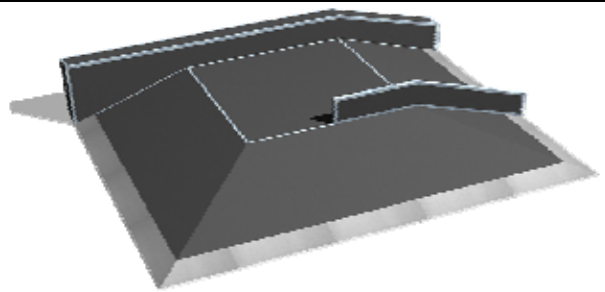
| Pyramide | L | B | H | Fahrbelag | | |
|---|------|------|------|-----------|--------------|--------------|
| | | | | GFK | Beton | |
|  | 6,00 | 4,40 | 0,60 | Nr. | 0,00 | 0,00 |
| | | | | | 17-1200060-K | 17-1200060-C |

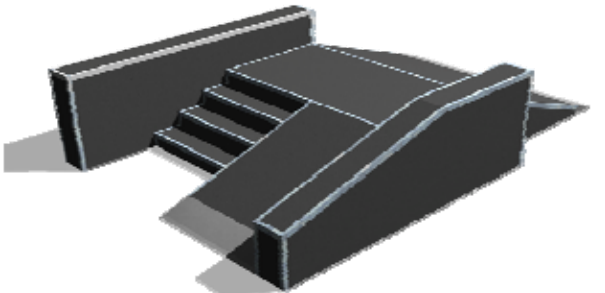
| fly over | L | B | H | Fahrbelag | | |
|---|------|------|------|-----------|--------------|--------------|
| | | | | GFK | Beton | |
|  | 4,60 | 3,00 | 0,60 | Nr. | 0,00 | 0,00 |
| | | | | | 18-1200060-K | 18-1200060-C |

Fun-Box

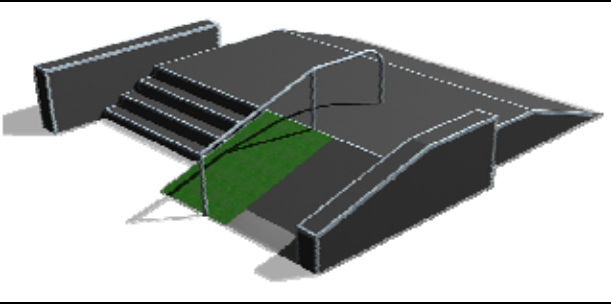
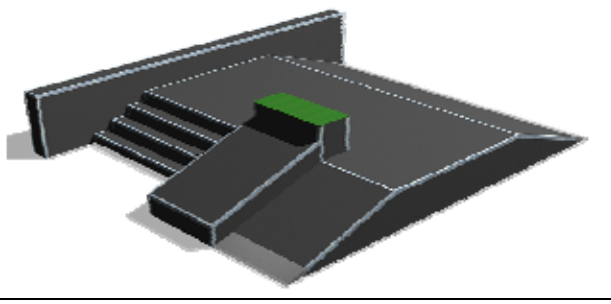
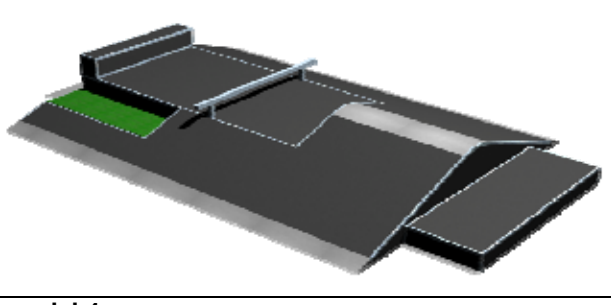
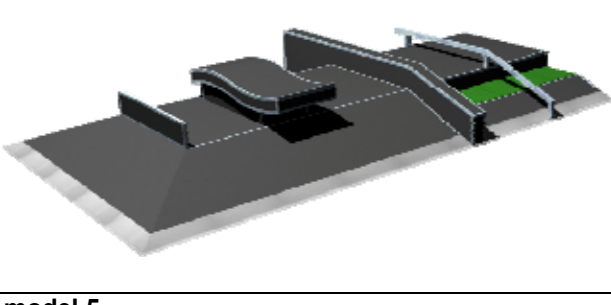
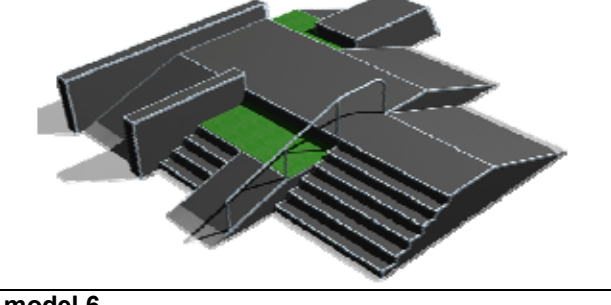
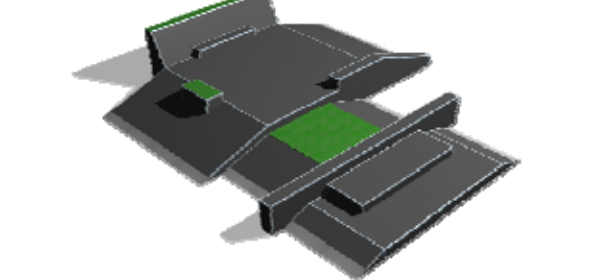
| | | | | Fahrbelag | | | | | |
|---|--|--|--|-----------|----------|----------------------|-----|--------------|--------------|
| | | | | GFK | Beton | | | | |
| model 1 | | | | L | B | H | | | |
|  | | | | 5,80 | 5,40 | 0,60 | Nr. | 0,00 | 0,00 |
| | | | | | | | | 19-1200060-K | 19-1200060-C |
| model 2 | | | | | | | | | |
|  | | | | 6,30 | 5,10 | 0,60 | Nr. | 0,00 | 0,00 |
| | | | | | | | | 20-1200060-K | 20-1200060-C |
| model 3 | | | | | | | | | |
|  | | | | 8,40 | 5,80 | 0,60 0,95 | Nr. | 0,00 | 0,00 |
| | | | | | | | | 21-1200060-K | 21-1200060-C |
| model 4 | | | | | | | | | |
|  | | | | 10,50 | 6,00 | 0,60 | Nr. | 0,00 | 0,00 |
| | | | | | | | | 22-1200060-K | 22-1200060-C |
| model 5 | | | | | | | | | |
|  | | | | 8,70 | 7,20 | 0,60 0,90 | Nr. | 0,00 | 0,00 |
| | | | | | | | | 23-1200090-K | 23-1200090-C |
| model 6 | | | | | | | | | |
|  | | | | 10,50 | 9,60 | 0,35 0,60 0,90 | Nr. | 0,00 | 0,00 |
| | | | | | | | | 24-1200090-K | 24-1200090-C |

Ramp`s

Quarter-Pipe

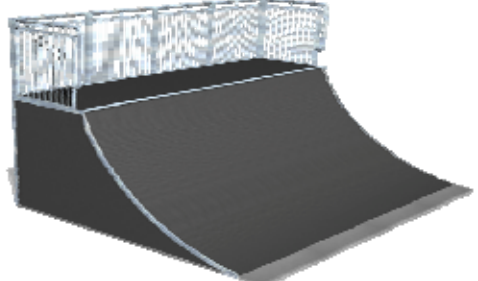
| | L | B | H | Fahrbelag | | |
|---|------|------|------|-----------|-----------------------------|-----------------------------|
| | | | | GFK | Beton | |
|  | 3,60 | 2,40 | 1,25 | Nr. | 0,00 25-1200125-K | 0,00 25-1200125-C |
| | 4,00 | 3,60 | 1,80 | Nr. | 0,00 25-1200180-K | 0,00 25-1200180-C |
| | 4,00 | 4,80 | 1,80 | Nr. | 0,00 25-1204180-K | 0,00 25-1204180-C |

Roll-In Ramp

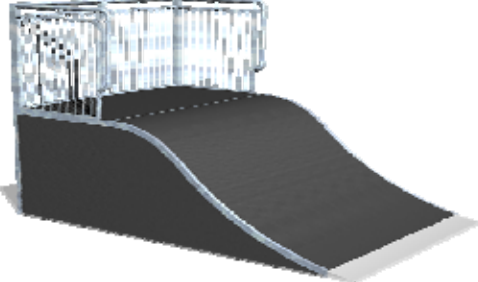
| | | | | | | |
|---|------|------|------|-----|-----------------------------|-----------------------------|
|  | 4,00 | 2,40 | 1,25 | Nr. | 0,00 26-1200125-K | 0,00 26-1200125-C |
| | | | | | | |

Bank

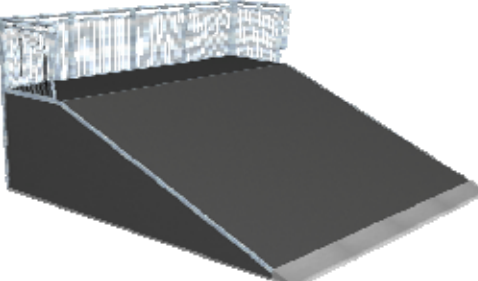
| | | | | | | |
|--|------|------|------|-----|-----------------------------|-----------------------------|
|  | 4,00 | 2,40 | 1,25 | Nr. | 0,00 27-1200125-K | 0,00 27-1200125-C |
| | 5,00 | 3,60 | 1,80 | Nr. | 0,00 27-1200180-K | 0,00 27-1200180-C |
| | 5,00 | 4,80 | 1,80 | Nr. | 0,00 27-1204180-K | 0,00 27-1204180-C |

Quarter-Bank-Quarter

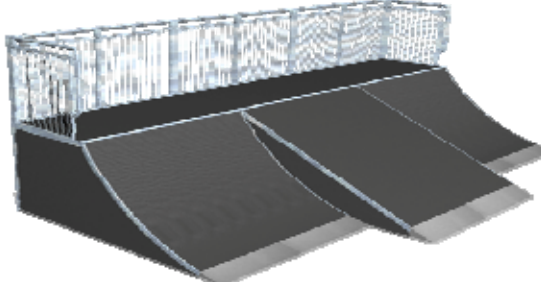
| | | | | | | |
|---|------|------|------|-----|-----------------------------|-----------------------------|
|  | 4,00 | 7,20 | 1,25 | Nr. | 0,00 28-1200125-K | 0,00 28-1200125-C |
| | | | | | | |

Corner-Ramp

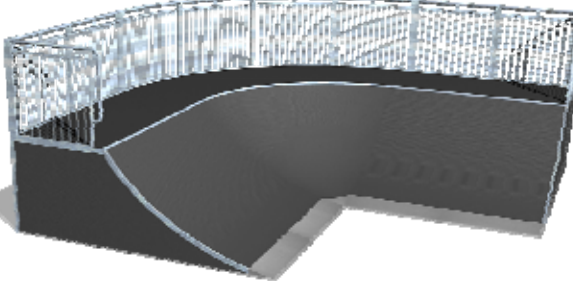
| | | | | | | |
|---|------|------|------|-----|-----------------------------|-----------------------------|
|  | 5,60 | 5,60 | 1,25 | Nr. | 0,00 29-1200125-K | 0,00 29-1200125-C |
| | | | | | | |

Corner-Bank

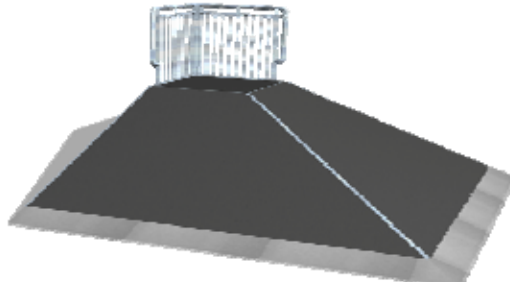
| | | | | | | |
|---|------|------|------|-----|-----------------------------|-----------------------------|
|  | 3,50 | 3,50 | 0,90 | Nr. | 0,00 30-1200090-K | 0,00 30-1200090-C |
| | 4,00 | 4,00 | 1,25 | Nr. | 0,00 30-1200125-K | 0,00 30-1200125-C |

Ramp`s

Quarter-wall ride

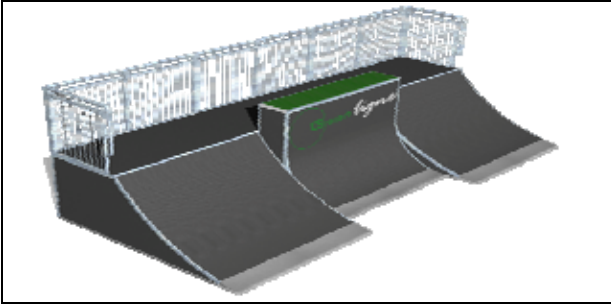

| | | | | Fahrbelag | |
|------|------|------|-----|-----------------------------|-----------------------------|
| L | B | H | | GFK | Beton |
| 3,60 | 7,20 | 1,25 | Nr. | 0,00 31-1200125-K | 0,00 31-1200125-C |

big Wave

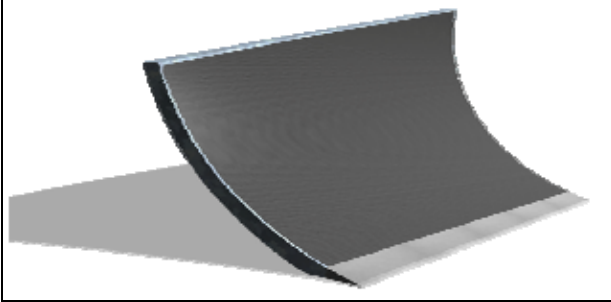

| | | | | | |
|------|------|--------------|-----|-----------------------------|-----------------------------|
| 2,00 | 6,00 | 1,80 2,50 | Nr. | 0,00 32-1200250-K | 0,00 32-1200250-C |
|------|------|--------------|-----|-----------------------------|-----------------------------|

China-Bank

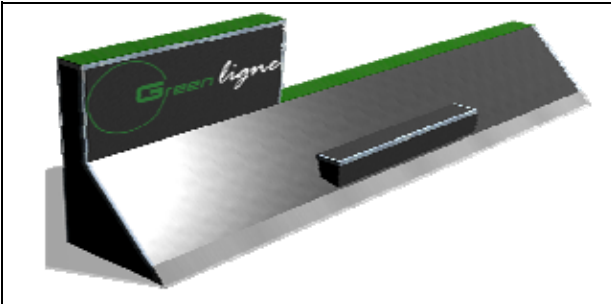

| | | | | | |
|------|------|------|-----|-----------------------------|-----------------------------|
| 1,50 | 7,20 | 1,00 | Nr. | 0,00 33-1200125-K | 0,00 33-1200125-C |
|------|------|------|-----|-----------------------------|-----------------------------|

Quarter-Pipe mit Hip

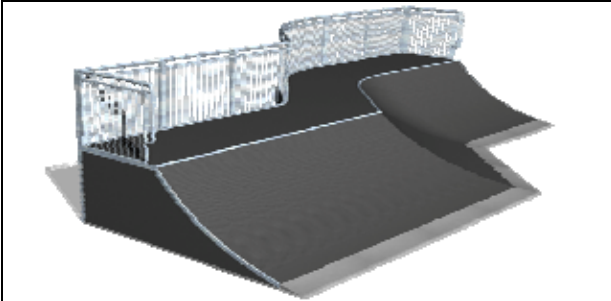

| | | | | | |
|------|------|------|-----|-----------------------------|-----------------------------|
| 5,00 | 9,00 | 1,25 | Nr. | 0,00 34-1200125-K | 0,00 34-1200125-C |
|------|------|------|-----|-----------------------------|-----------------------------|

wall-Ramp

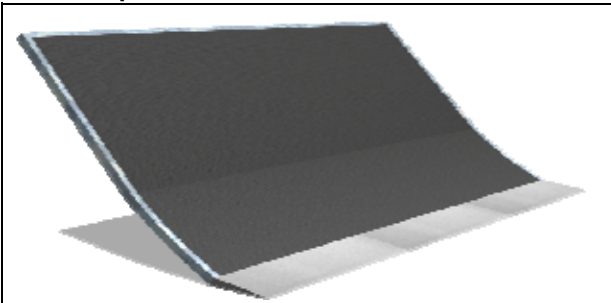

| | | | | | |
|------|------|------|-----|-----------------------------|-----------------------------|
| 1,80 | 3,60 | 1,50 | Nr. | 0,00 35-1200108-K | 0,00 35-1200180-C |
|------|------|------|-----|-----------------------------|-----------------------------|

Plaza Bank

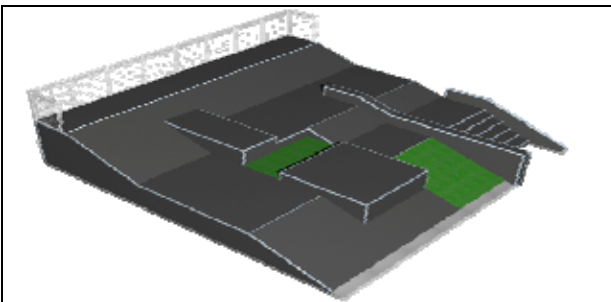

| | | | | | |
|------|------|----------------------|-----|-----------------------------|-----------------------------|
| 9,70 | 9,60 | 0,90 1,25 1,80 | Nr. | 0,00 36-1200180-K | 0,00 36-1200180-C |
|------|------|----------------------|-----|-----------------------------|-----------------------------|

Half-Pipe`s

Mini-Pipe



| | | | | Fahrbelag | |
|-------|------|------|-----|-----------------------------|-----------------------------|
| L | B | H | | GFK | Beton |
| 10,00 | 3,60 | 1,25 | Nr. | 0,00 37-1200125-K | 0,00 37-1200125-C |
| 10,00 | 4,80 | 1,25 | Nr. | 0,00 37-1204125-K | 0,00 37-1204125-C |

Midi-Pipe



| | | | | | |
|-------|------|------|-----|-----------------------------|-----------------------------|
| 10,50 | 3,60 | 1,80 | Nr. | 0,00 38-1200180-K | 0,00 38-1200180-C |
| 10,50 | 4,80 | 1,80 | Nr. | 0,00 38-1204180-K | 0,00 38-1204180-C |

Kombi-Pipe

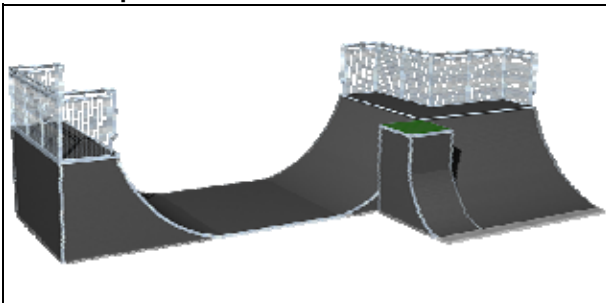

| | | | | | |
|-------|------|------|-----|-----------------------------|-----------------------------|
| 13,00 | 6,50 | 1,80 | Nr. | 0,00 39-1200180-K | 0,00 39-1200180-C |
|-------|------|------|-----|-----------------------------|-----------------------------|

Kombi-Pipe II

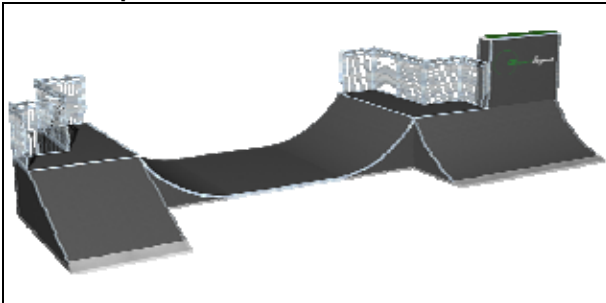

| | | | | | |
|-------|------|--------------|-----|-----------------------------|-----------------------------|
| 14,20 | 6,20 | 0,90 1,25 | Nr. | 0,00 40-1200125-K | 0,00 40-1200125-C |
|-------|------|--------------|-----|-----------------------------|-----------------------------|

Half-Pipe

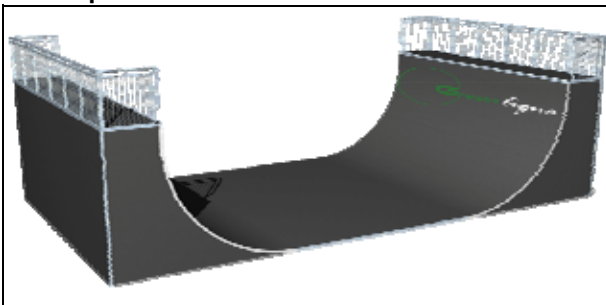

| | | | | | |
|-------|------|------|-----|-----------------------------|-----------------------------|
| 13,50 | 7,20 | 3,45 | Nr. | 0,00 41-1200345-K | 0,00 41-1200345-C |
|-------|------|------|-----|-----------------------------|-----------------------------|

Competition Pipe mit Channel und Roll In



| | | | | | |
|-------|-------|--------------|-----|-----------------------------|-----------------------------|
| 14,50 | 12,00 | 3,90 4,90 | Nr. | 0,00 42-1200390-K | 0,00 42-1200390-C |
|-------|-------|--------------|-----|-----------------------------|-----------------------------|

Plaza

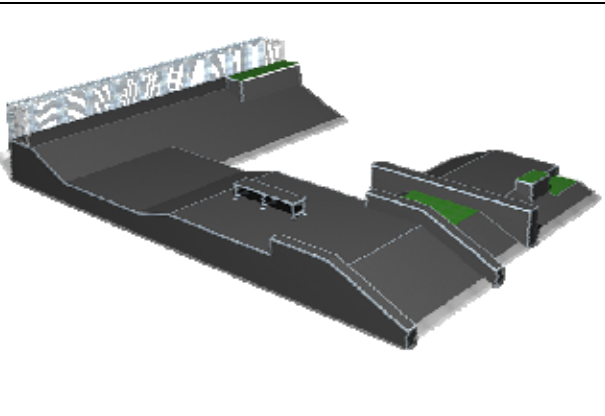
| P1 | L | B | H | Fahrbelag | | |
|---|-------|-------|----------------------|-----------|----------------------|----------------------|
| | | | | GFK | Beton | |
|  | 16,50 | 13,20 | 0,60 0,90 1,25 | Nr. | 0,00 43-1200125-K | 0,00 43-1200125-C |
| | | | | | | |

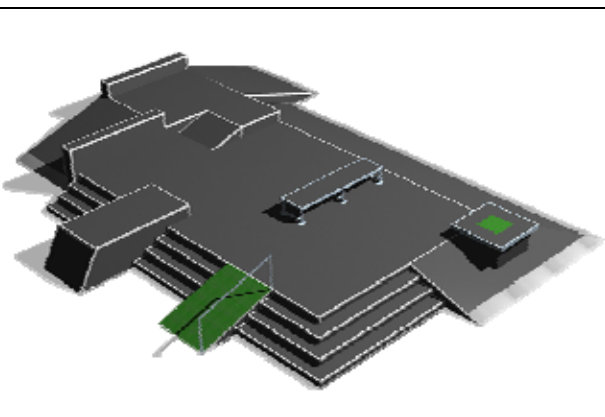
| P2 | L | B | H | Fahrbelag | | |
|---|-------|------|--------------|-----------|----------------------|----------------------|
| | | | | GFK | Beton | |
|  | 11,00 | 9,50 | 0,60 0,90 | Nr. | 0,00 44-1200090-K | 0,00 44-1200090-C |
| | | | | | | |

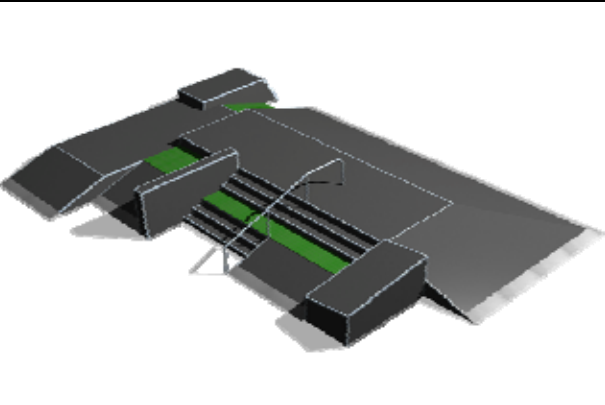
| P3 | L | B | H | Fahrbelag | | |
|---|-------|------|--------------|-----------|----------------------|----------------------|
| | | | | GFK | Beton | |
|  | 12,00 | 9,00 | 0,60 0,90 | Nr. | 0,00 45-1200090-K | 0,00 45-1200090-C |
| | | | | | | |

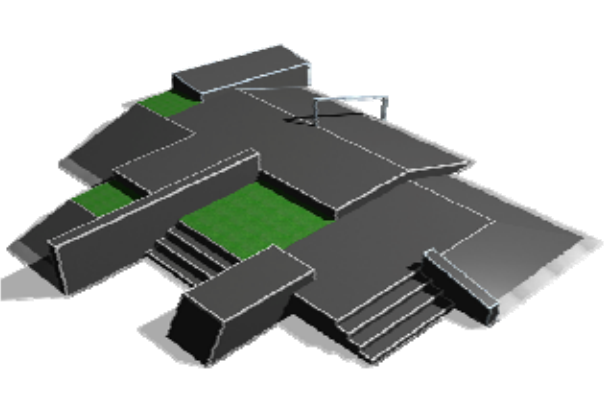
| P4 | L | B | H | Fahrbelag | | |
|---|-------|-------|--------------|-----------|----------------------|----------------------|
| | | | | GFK | Beton | |
|  | 11,00 | 10,00 | 0,60 0,90 | Nr. | 0,00 46-1200090-K | 0,00 46-1200090-C |
| | | | | | | |

mobile Skate park

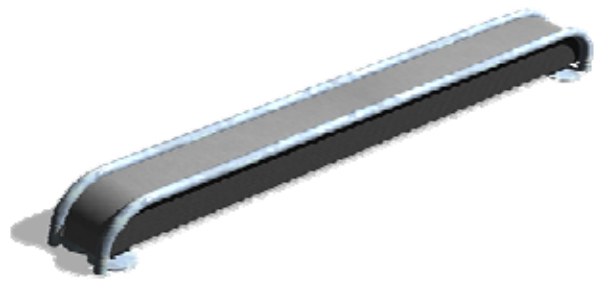
| | | | | | |
|--|----------|----------|----------|--|------------------|
| curb  | L | B | H | | Fahrbelag |
| | 2,40 | 0,30 | 0,25 | | GFK |

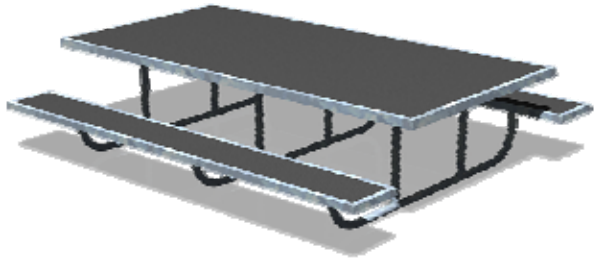
| | | | | | |
|--|------|------|------|--|--|
| picnic-Table  | 1,90 | 1,30 | 0,70 | | |
| | | | | | |

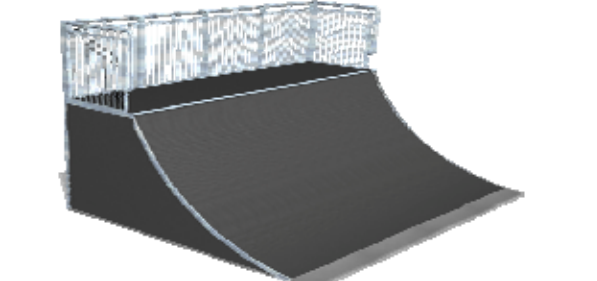
| | | | | | |
|---|------|------|------|--|--|
| Quarter-Pipe  | 3,00 | 2,40 | 1,20 | | |
| | | | | | |

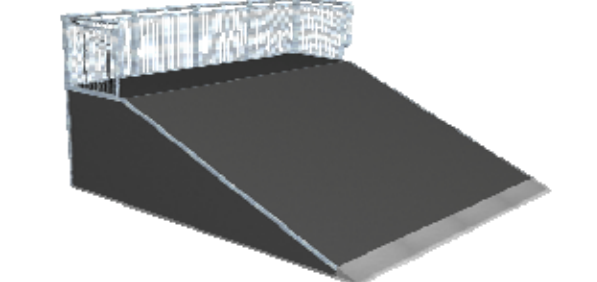
| | | | | | |
|--|------|------|------|--|--|
| Bank  | 3,30 | 2,40 | 1,20 | | |
| | | | | | |

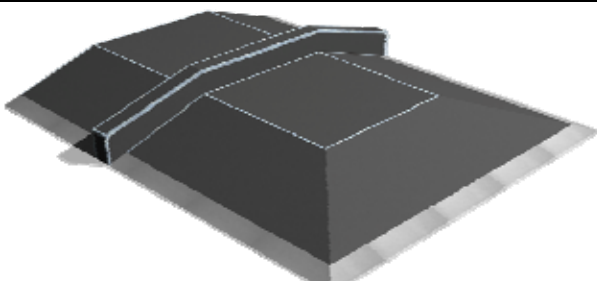
| | | | | | |
|---|------|------|------|--|--|
| Fun-Box  | 6,50 | 5,60 | 0,60 | | |
| | | | | | |

| | | | | | |
|--|------|------|------|--|-------------|
| mobile street Skate park  | 4,70 | 2,20 | 3,00 | | 0,00 |
| | | | | | SP-M500-K |

Skate Park Technik & Details

Skatepark Equipment für **Inline - Skateboard - BMX** Anlagen nach **EN 14974**

Konstruktion

Feuerverzinkte Stahlrohrkonstruktion mit **Einstellfüßen** zur Niveauregelung.
360° Stahlrahmen Kantenschutz für Fahrbeläge

Fahrbeläge:

- ▶ **GFK:** 10mm glasfaserverstärkte Kunststoffplatten
in allen RAL Farben lieferbar; Standardfarbe: Grau
zweifache Lärmschutzeinlage mit Schwingungsdämpfer
- ▶ **Beton:** 10mm glasfaserverstärkte Betonplatten
Standardfarbe: Grau
zweifache Lärmschutzeinlage mit Schwingungsdämpfer

Seitenverkleidungen:

- ▶ **GFK:** 8mm glasfaserverstärkte Kunststoffplatten
in allen RAL Farben lieferbar; Standardfarbe: Grau
- ▶ **Beton:** 8mm glasfaserverstärkte Betonplatten
Standardfarbe: Grau

Anfahrtsplatten:

- ▶ **Edelstahl:** 3mm vorgeformte Edelstahlplatten
für eine dauerhafte und optimale Anfahrt.



green area

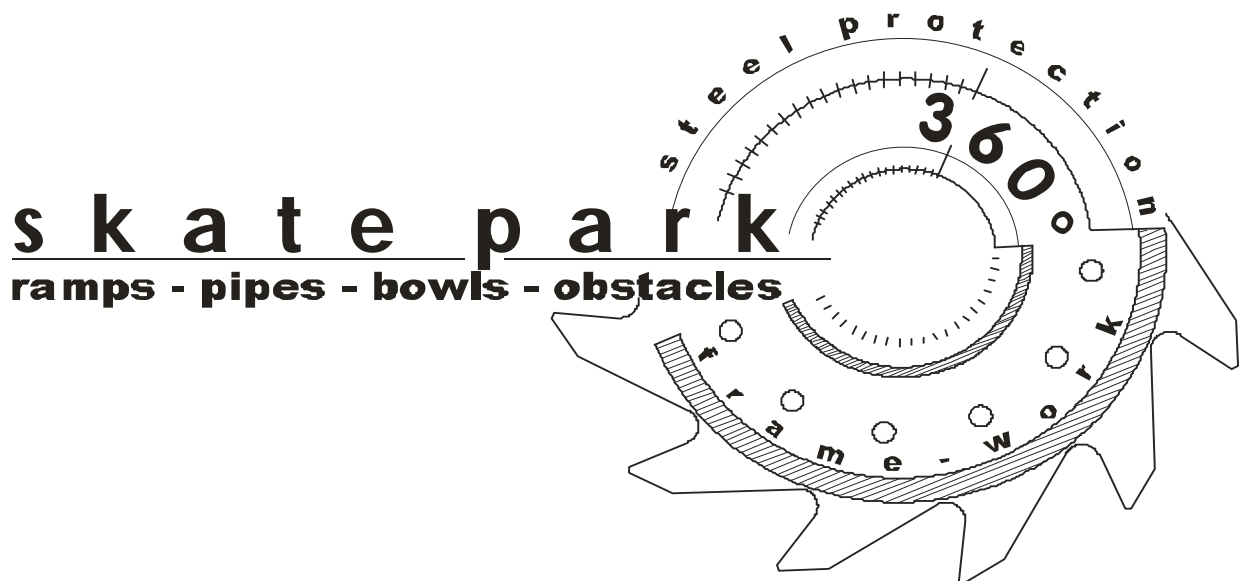



Schallpegelmessung Skatergeräte dB(A)

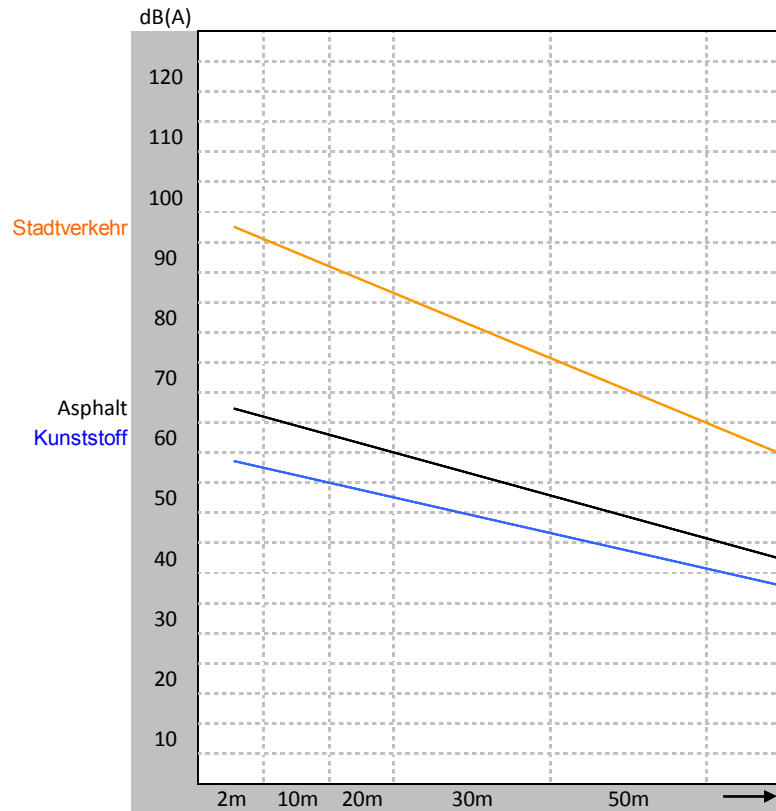

Skateanlagen Messung energetische Mittelwerte der Rollgeräusche von Skateboardern. Zur Messung wurden handelsübliche Skateboardrollen aus Plastik verwendet. Werte stehen in Abhängigkeit zu den verschiedenen Materialien von Skateboardrollen und können variieren.
 Rollgeräusche von Inline-Fahrern mit Gummi Rollen sind weit unter den Werten von Skateboardern und wurden nicht berücksichtigt.
 Unterschied liegt bei ca. 20% !

Mittelwert: Spielbetrieb von ca. 10 Personen in einer Entfernung von 10m.

| | dB(A) |
|------------|--------|
| Skateplatz | ca. 70 |
| Spielplatz | ca. 60 |